

The Challenge Machinery Company provides owner's manuals on its products solely as a courtesy to its customers. See the information below before using this manual.

These manuals are for reference only. These manuals include products which are noncurrent, unsupported or no longer produced by The Challenge Machinery Company, and are provided solely as an accommodation to our customers. By providing these manuals, The Challenge Machinery Company makes no representation or warranty as to the products, their current condition, or their suitability or fitness for use in any particular application, which are the sole and independent responsibility of the product owner and user.

Older products may not comply with current safety procedures, guidelines or regulations, and it is the product owner's and user's responsibility to evaluate the suitability and fitness of the products in their current use and application. The Challenge Machinery Company makes no representation, warranty or recommendation regarding any modifications which may be required on non-current or unsupported products. The Challenge Machinery Company assumes no liability for any modification or alteration to any Challenge product, and any such modification or alteration to any Challenge product is not authorized by The Challenge Machinery Company. The availability of these manuals is solely for the purpose of providing reference information for the products.

This manual may not be complete in all aspects of product maintenance and repair. **All products should be used only by qualified and properly trained personnel, following proper safety procedures.** All products should be regularly inspected and maintained, and their condition, application and use should be periodically evaluated by qualified personnel. Only qualified and properly trained technicians should perform maintenance, repair and replacement procedures. Attempting these procedures without proper training may cause machine damage or operator injury!

Products may be unsupported by The Challenge Machinery Company due to age or the unavailability of parts from their original manufacturer. No parts or product support will be available to repair or maintain unsupported products. Older products may not be UL listed (if the product does not have a UL label it is not a listed product), and may not comply with applicable installation or other regulations or requirements if relocated to a new facility. Many municipalities require a product to be UL listed before an electrician will connect power to them. Often the cost of updating an older product to comply with current safety regulations is greater than the value of the product.



***HANDY-PADDER &
HANDY-PADDER WITH AIR
Instruction and Parts Manual***

Sold and Serviced by

The Challenge Machinery Company
6125 Norton Center Drive
Norton Shores, MI 49441-6081 USA

ChallengeMachinery.com

F.1730
August 2015

1.0 Warranty

*** WARRANTY INFORMATION ***

PLEASE REVIEW THE ENCLOSED WARRANTY INFORMATION SHEET

It is very important that you read and understand the conditions outlined in the *Warranty Information Sheet* attached to the outside of the shipping container of your machine.

The *Warranty Information Sheet* must be filled out completely and returned to THE CHALLENGE MACHINERY COMPANY in order for the warranty to be issued for this machine.

2.0 Specifications

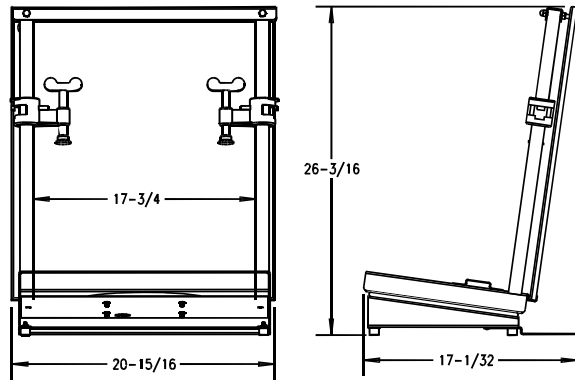

Maximum Lift Height	16" / 40.6 cm
Maximum Lift Width	17-3/4" / 45 cm
Lift Depth	4" to 13+" / 10 cm to 33+ cm
Capacity Example	14,000 8-1/2 x 11" 20# bond
Overall Base Area	20-15/16" / 53.2 cm
Overall Height	26-3/16" / 66.5 cm
Overall Length	17-1/32" / 43.3 cm
Net Weight (approx.)	50 lbs / 22.7 kg
Shipping Weight (approx.)	55 lbs / 25 kg

3.0 Installation and Operation

3.1 Installation

Remove the Handy-Padder from its carton. Place it on a table or countertop. If placing on a counter, the silver anti-tip support should face toward the wall.

3.2 Operation

1. Jog piles for padding and place on the padder table as shown below. The vertical bars may be used as left/right jogging stops. Jog the piles against the door and uprights. For proper clamping, clamp piles of equal thickness.



2. Place the clamp on top of the piles as shown. Slide the pipe clamps down the vertical bars. Firmly tighten the screws onto the clamping bar.



3. Rotate the table 180° in either direction until the table locks into place.

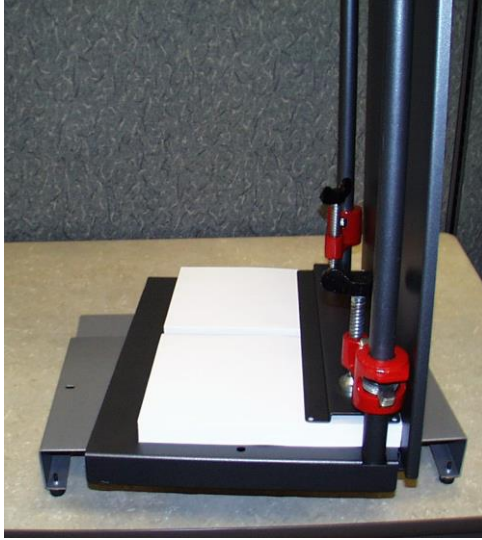

4. Remove the door by lifting it off its hanger screws. Apply padding compound to the exposed surfaces of the piles.



5. Allow the compound to dry for 10 to 20 minutes. Loosen the clamps and slide them out of the way. Remove the clamp bar and pads. Wipe compound from the lower door slot after each use.

3.3 Handy-Padder with Air Operation

Operate the Handy-Padder with Air as described above. However, after applying the compound, switch on the fans. The switch is located on the right-hand side of the base of the machine. Drying may also be accelerated by placing the door back onto the screws with the bottom of the door resting on the door of the fan compartment as shown in the figure below.

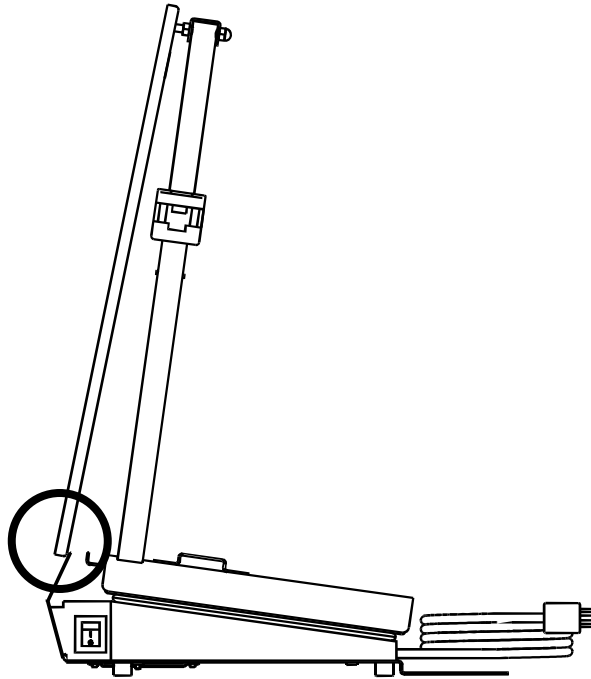

4.0 Padding Tips

Loading

The Handy-Padder table rotates on a turnstile so the operator can work from one side of the padder.

Counting

Set the printer to offset each book at the output bin of the printer to keep each pad the same thickness. It will also make it easier to insert chipboard.

If that's not possible, use a counter gauge. Count out one pad, measure it with the gauge and count the rest.

Brushing

With regular paper and regular compound, two thin coats will work better than one thick one.

When you're applying the compound, don't try to put the second coat on until the first coat is dry or the brush will stick to the compound of the first coat and ruin it.

The Compound

Regular padding compound tends to lose moisture the more it's used so by the time you get half way through the bottle it is pretty thick. To thin it out again, just add a little water and stir it. Don't add too much, or the compound will be too thin and curl the edge of the paper.

There are different formulations of compounds. There are 20 minute , 5 minute, and NCR compounds as well as colored compounds.

NCR

When padding NCR or self-bonding papers that must absorb the compound, don not use too much pressure on the clamps. The heavy pressure will squeeze the edge of the paper too tight and harden it so the compound cannot sink in. One coat usually works fine with this type of compound. Make sure the paper is good and dry before you release the pressure on the bar or the sets may not separate like they should.

Separating the Pads

To cut the pads apart, use an ink knife, paint scrapper, or kitchen knife. If the knife's edge is too sharp or square, it will cut into the paper rather than separate the pads. A rounded blade seems to work the best.

Cleaning

The edge of the clamping bar and the door slot in the table should be cleaned after each use. Use a padding knife to scrape the dried compound off the metal edges. Finish with a wet rag or sponge.

Sacrificial Sheet

To expedite clean-up, place sacrificial sheets at the bottom of the pile covering the slot in which the door sits. Discard the sheets after use.

Parts List

4.1 Main Assembly (without Air)

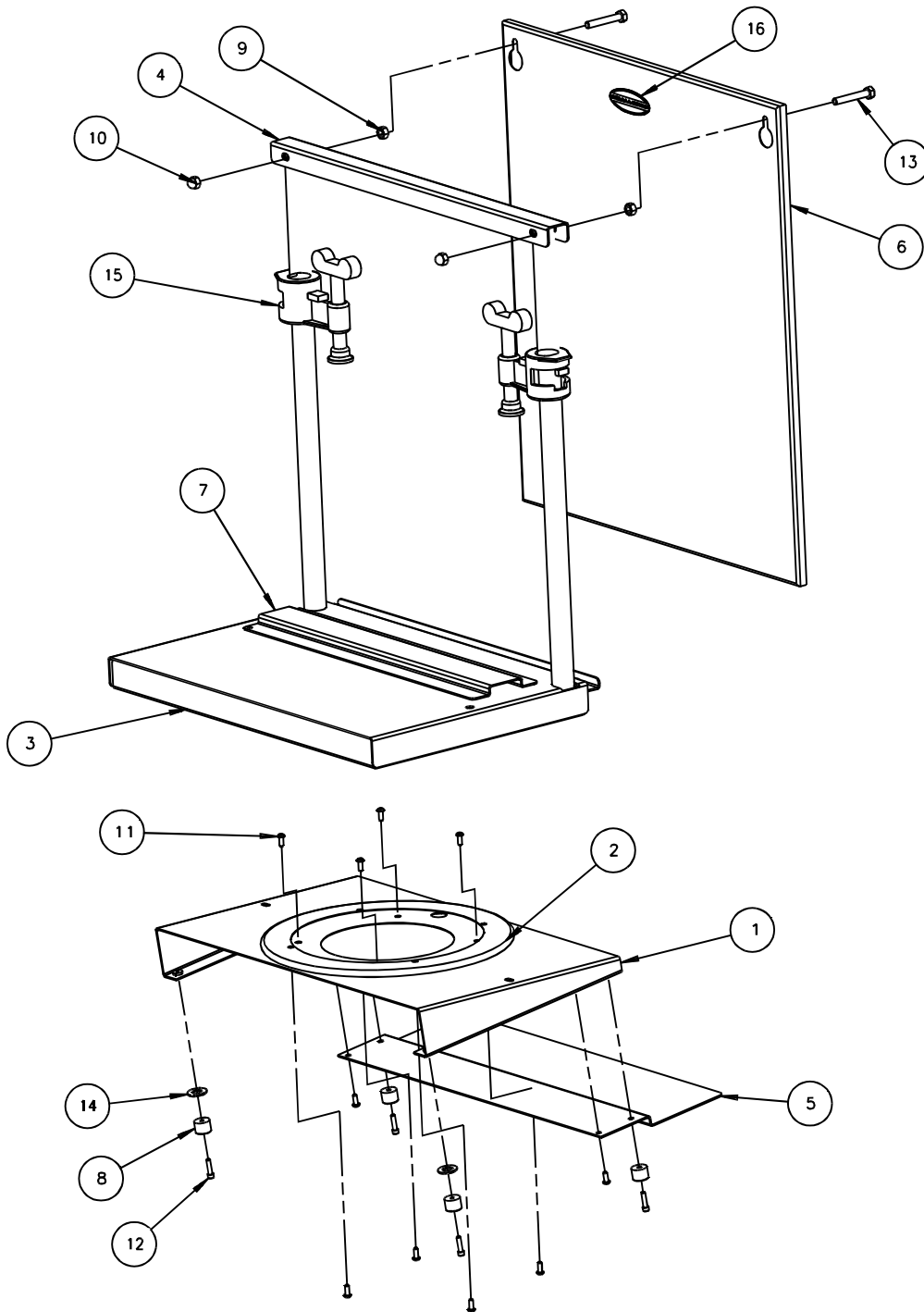

4.2 Main Assembly (continued)

ITEM	PART NO.	DESCRIPTION	QTY
1	65001	BASE	1
2	65002	TURNTABLE	1
3	65003	TABLE ASSEMBLY	1
4	65007	TIE BAR	1
5	65008	SUPPORT	1
6	65009	DOOR	1
7	65010	CLAMP	1
8	A-11074	FOOT - RUBBER	4
9	H-6417-5	NUT - 5/16-18 HEX	2
10	H-6431-5	NUT - 5/16-18 ACORN CAP	2
11	H-6910-102403	SCREW - #10-24 X 1/2 BUTTON HEAD CAP	10
12	H-6918-102406	SCREW - #10-24 X 3/4 SOCKET HEAD CAP	4
13	H-6992-516	SCREW - 5/16-18 X 2 FULL THD HEX HD	2
14	H-7321-6	WASHER - 3/8 SAE PLAIN	2
15	S-1882	3/4" PIPE CLAMP	2
16	S-1076-2	CHALLENGE LABEL	1

4.3 Main Assembly (with Air)

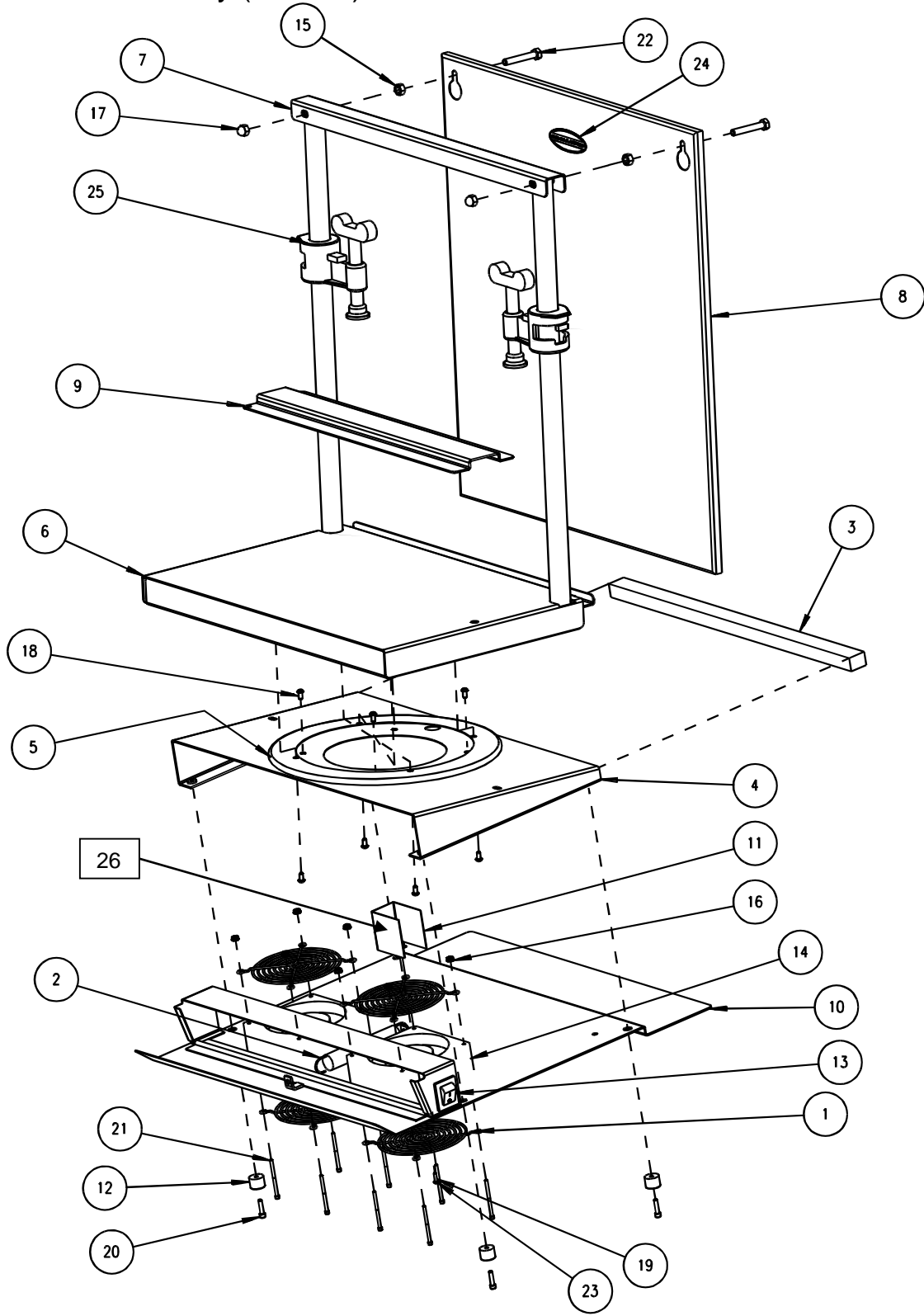

4.4 Main Assembly (with Air, continued)

ITEM	PART NO.	DESCRIPTION	QTY
1	47092	GUARD - FAN	4
2	47136-4	EXTENSION SPRING	1
3	47163-	GASKET	1
4	65001	BASE	1
5	65002	TURNTABLE	1
6	65003	TABLE ASSEMBLY	1
7	65007	TIE BAR	1
8	65009	DOOR	1
9	65010	CLAMP	1
10	65018	AIR BLOWER BASE	1
11	65022	SWITCH COVER	1
12	A-11074	FOOT - RUBBER	4
13	E-1140-11	ROCKER SWITCH	1
14	E-2483	FAN	2
15	H-6417-5	NUT - 5/16-18 HEX	2
16	H-6423-#6	NUT - #6-32 HEX KEP	8
17	H-6431-5	NUT - 5/16-18 ACORN CAP	2
18	H-6910-102403	SCREW - #10-24 X 3/8 BUTTON HEAD CAP	8
19	H-6910-63204	SCREW - #6-32 X 1/2 BUTTON HEAD CAP	1
20	H-6918-102406	SCREW - #10-24 X 3/4 SOCKET HEAD CAP	4
21	H-6918-63216	SCREW - #6-32 X 2 SOCKET HEAD CAP	8
22	H-6992-516	SCREW - 5/16-18 X 2 FULL THD HEX HD	2
23	H-7324-#6	WASHER - #6 INT TOOTH	1
24	S-1076-2	CHALLENGE LABEL	1
25	S-1882	3/4" PIPE CLAMP	2
26	S-1781-113	LABEL- SHOCK HAZARD	1

4.5 Wiring Diagram- E-3176 Rev. "A"

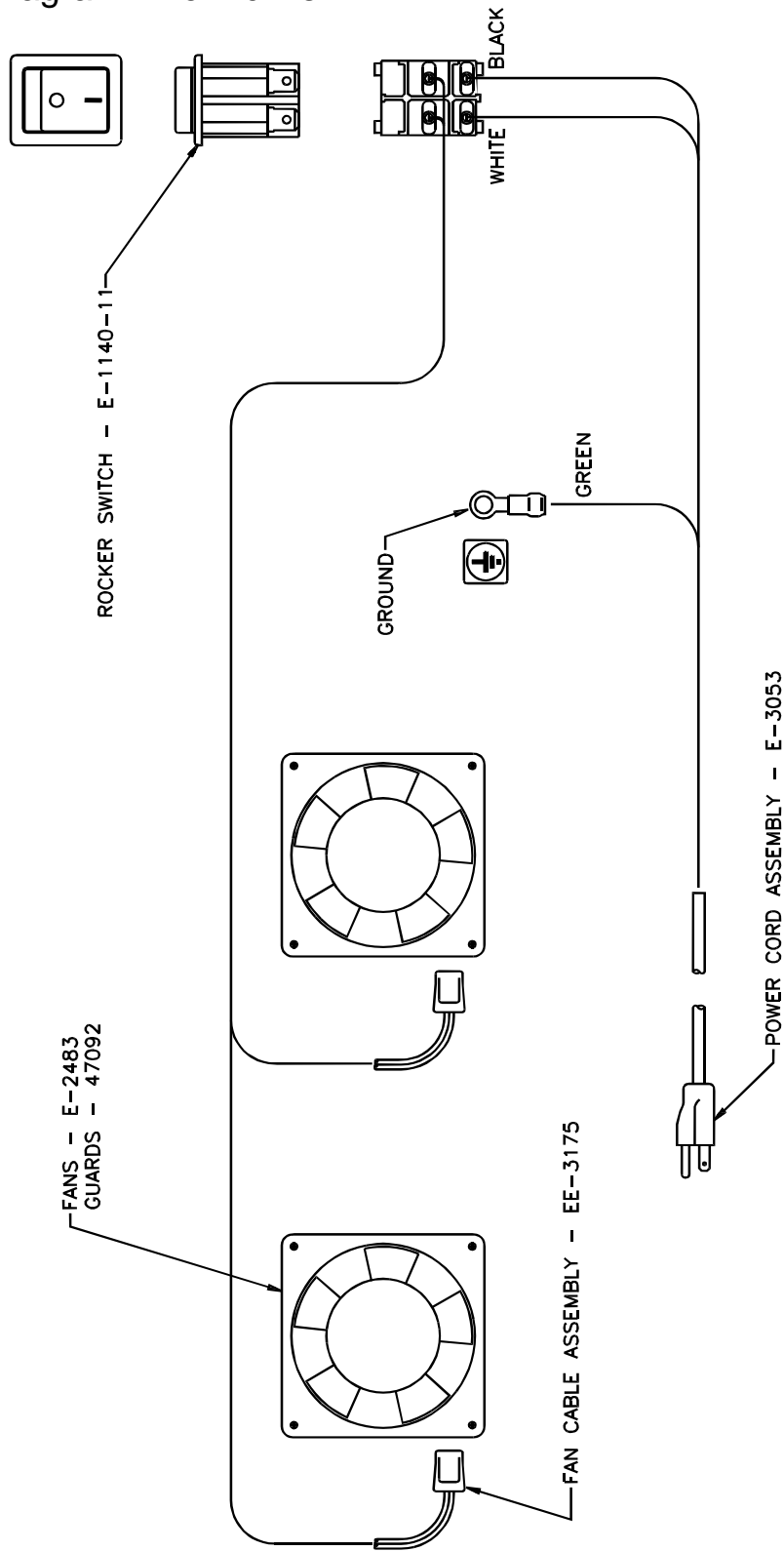

Notes:

